

4009059(Black), 4009219(Gold)

Metal Daybed and Trundle

Twin/Twin

Weight Limit:
Daybed:400 LBS / 181 KG
Trundle:250 LBS / 113 KG

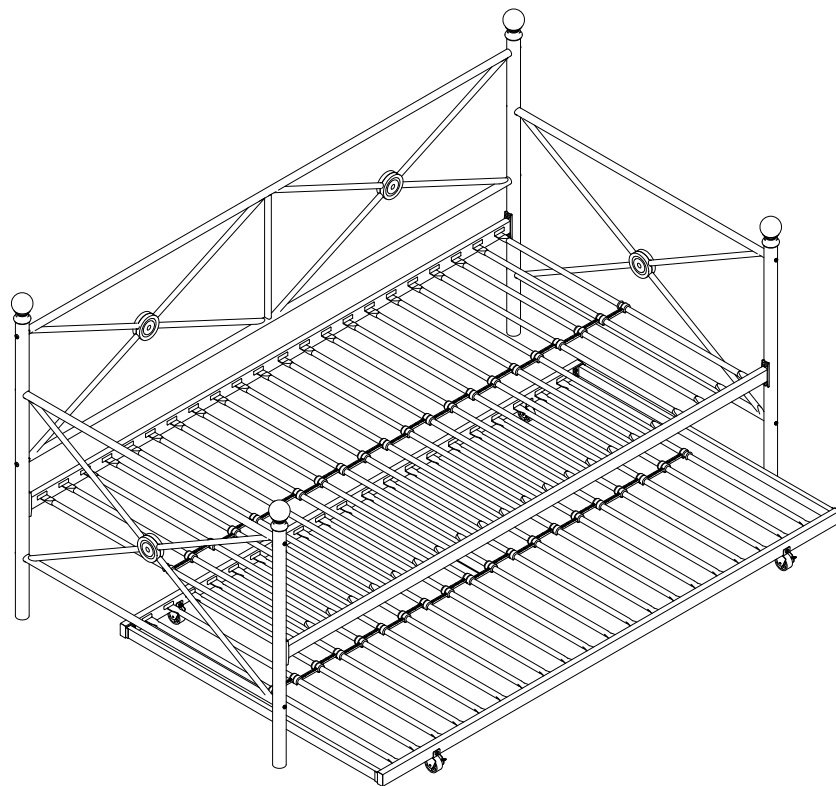

Thank you for purchasing from DHP!

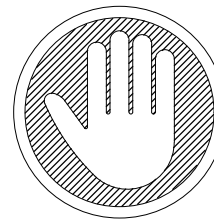

Questions, concerns, missing parts?
**CONTACT OUR CUSTOMER SERVICE
DEPARTMENT BEFORE RETURNING PRODUCT
TO THE RETAILER.**

If parts are missing or damaged, we will gladly ship your replacement parts free of charge.

Visit www.dhpfurniture.com/eng/replacement-parts
or call Toll-Free **1-800-267-1739**

You can also chat with us at www.dhpfurniture.com

Date of Purchase

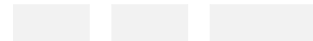

Lot Number (TAKEN FROM CARTON)

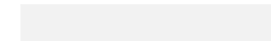

	<p>VISIT THE DHP HELP CENTER FOR ASSEMBLY VIDEOS AND MORE! helpcenter.dhpfurniture.com</p> <p>OR SCAN ME TO THERE! </p>	
--	--	--

! THIS INSTRUCTION BOOKLET CONTAINS **IMPORTANT** SAFETY INFORMATION. PLEASE READ AND KEEP FOR FUTURE REFERENCE.

Limited 1 year Warranty

DHP warrants this product to be free from defects in material and workmanship and agrees to remedy any such defect. This warranty covers one year from the date of original purchase from authorized retailers. This is solely limited to the repair or replacement of defective parts and assembly labor is not included.

This warranty does not apply to any product which has been improperly assembled, subjected to misuse or abuse or which has been altered or repaired in any way. The warranty does not cover wearing, tearing, fading or splitting of the fabric (where applicable). Liability for consequential damages is excluded to the extent exclusion is permitted by law. This warranty gives you specific legal rights and you may also have other rights which vary from state to state or province to province.

To obtain warranty service, purchaser must present original bill of sale. Components repaired or replaced are warranted through the remainder of the original warranty period only. The defective components will be repaired or replaced without charge, subject to the terms and conditions described above.

The terms and conditions of the limited warranty are subject to change without notice. For the latest warranty policy, please visit www.dhpfurniture.com.

Contact Us!

For help with assembly, identifying parts, product information or to order parts, please contact us:



www.dhpfurniture.com



cs@dhpfurniture.com



1-800-267-1739

Monday to Friday **9 am to 9 pm** (Eastern Time)
Saturday **10 am to 6:30 pm** (Eastern Time)
Sunday **11 am to 7 pm** (Eastern Time)



DHP Consumer Services

12345 Albert Hudon, Suite 100,
Montreal, Quebec H1G 3L1

Read Before Beginning Assembly

- Work in a spacious area and near where the unit will be used, preferably on a carpet, or use a piece of the cardboard packaging to protect your floor and product.
- Make sure all parts are included. Most parts are labeled or stamped on the raw edge.
- Read each step carefully. It is very important that each step of the instructions is performed in the correct order. If these steps are not followed in sequence, assembly difficulties will occur.
- This product may contain small components. Please ensure that they are kept away from small children.
- This product is designed for home use and is not intended for commercial use.

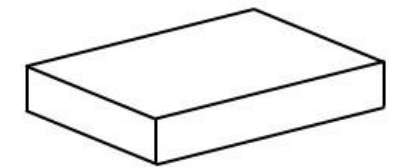
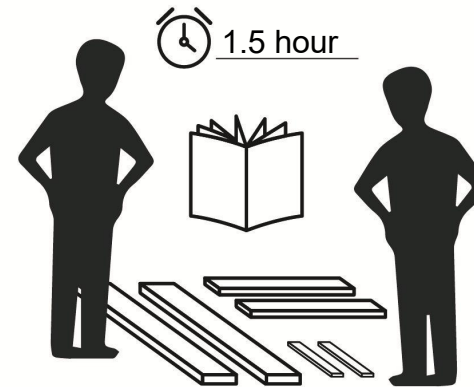

This product is shipped in
1 carton

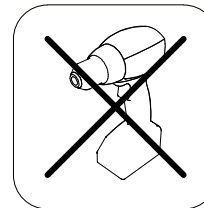

Do NOT use
powertools



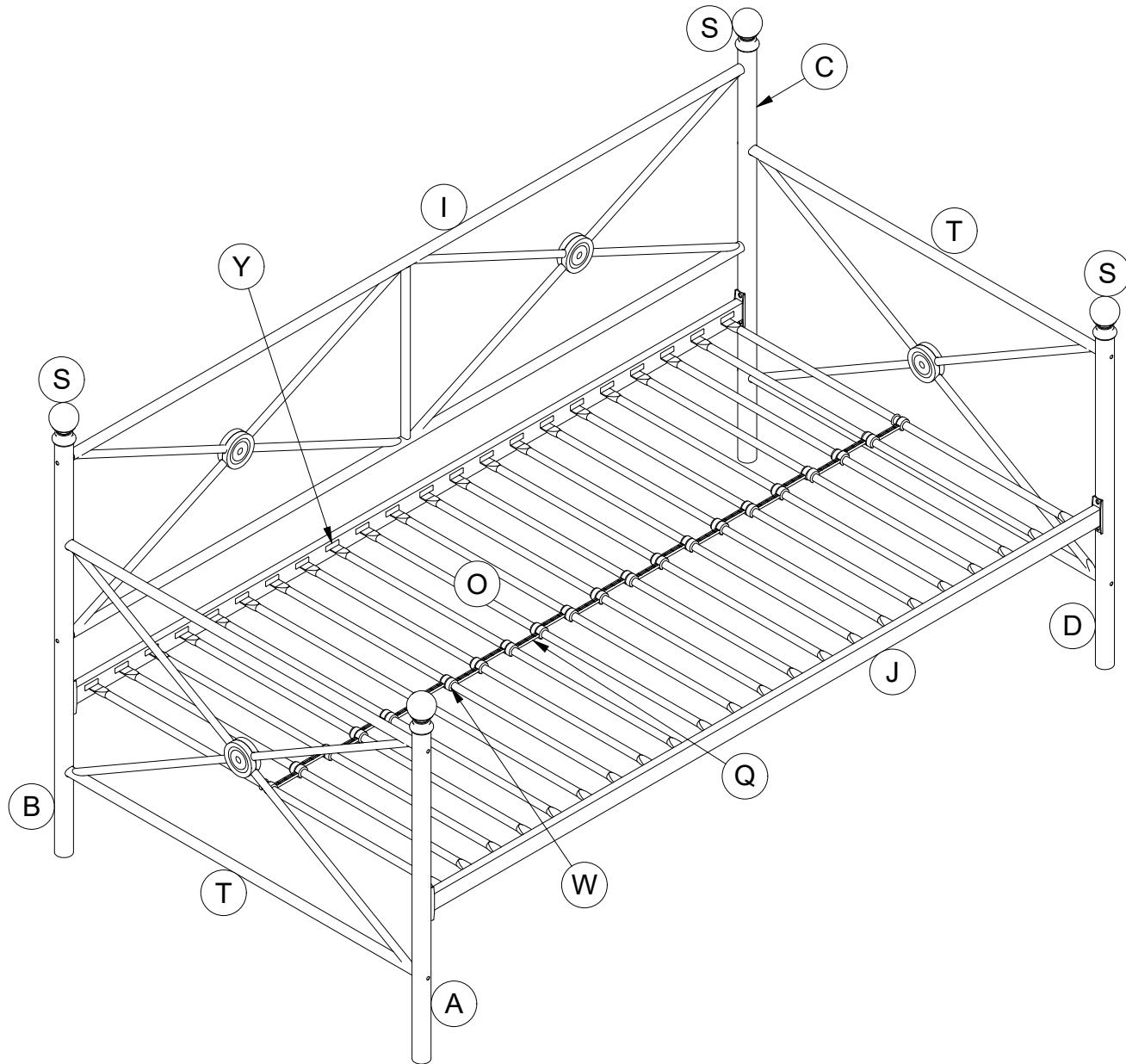

PARTS FOR DAYBED

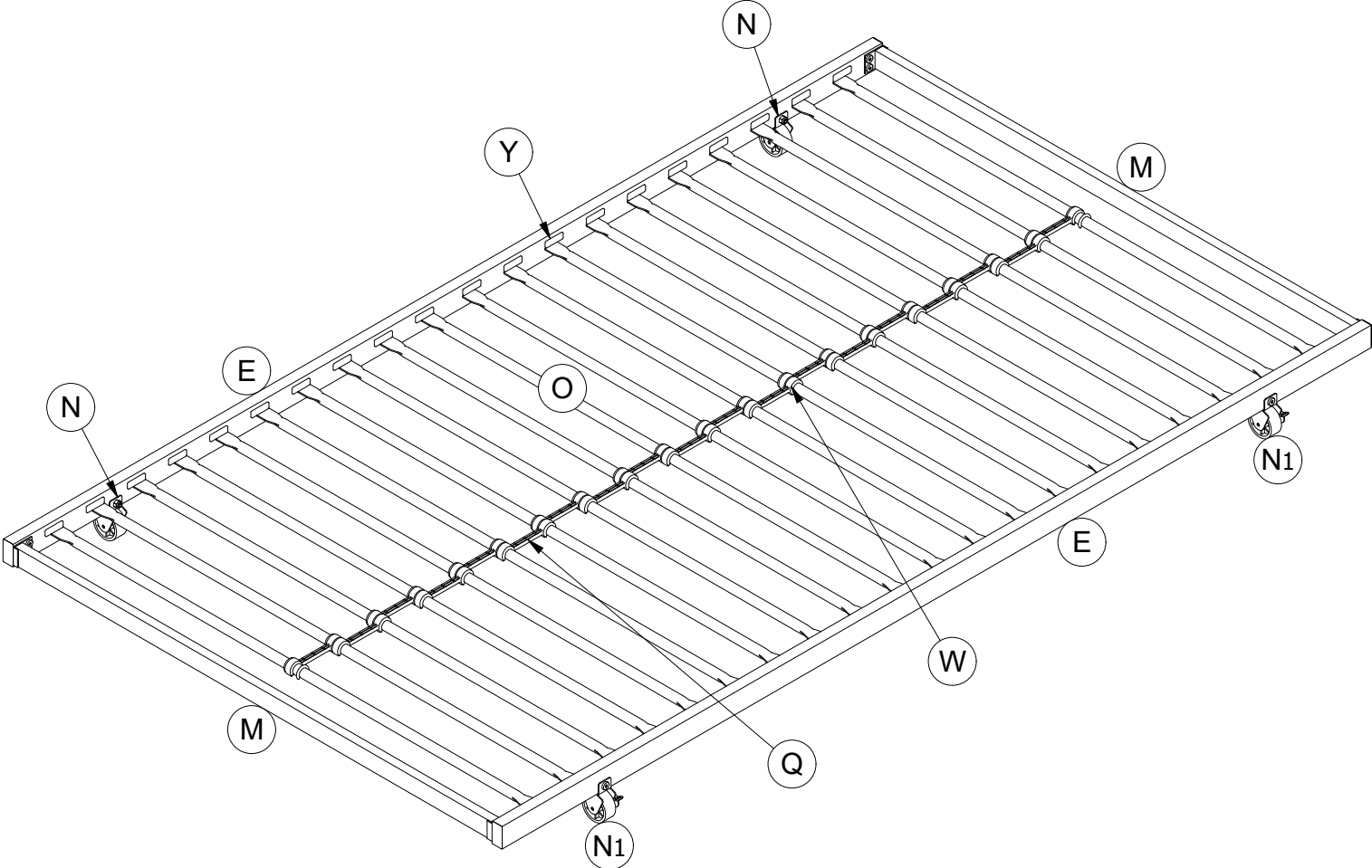

PARTS FOR TRUNDLE

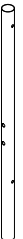
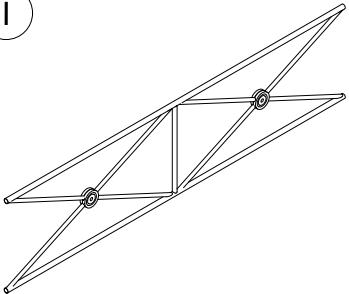
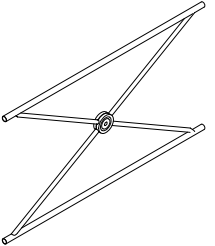
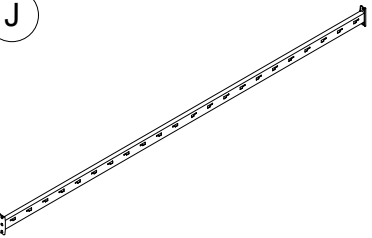
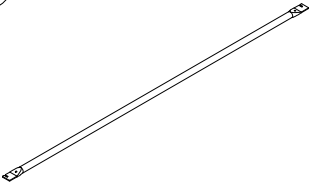
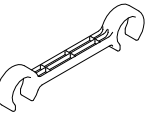
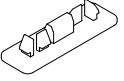

PARTS LIST FOR DAYBED





					
A Post 1 PC	B Post 1 PC	C Post 1 PC	D Post 1 PC	I Rear Guard Rail 1 PC	T Side Guard Rail 2 PCS
					
J Side Rail 2 PCS	O Slat 22 PCS	Q Slat Spacer 21 PCS	Y Plastic plug 44 PCS	W Slat Spacer 22 PCS	S Ball 4 PCS

PART NUMBERS		
PART LABELS	4009059(Black)	4009219(Gold)
A	T926040	T958020
B	T926050	T958030
C	T926060	T958040
D	T926070	T958050
I	T926080	T958060
T	T926100	T958070
J	T922140	T947170
O	T919600	T945890
Q	T919490	T919490
Y	T392590	T392590
W	T919480	T919480
S	T925650	T946790

⚠ Each part has a unique part number. Please reference the appropriate part number when contacting customer service for replacement parts.

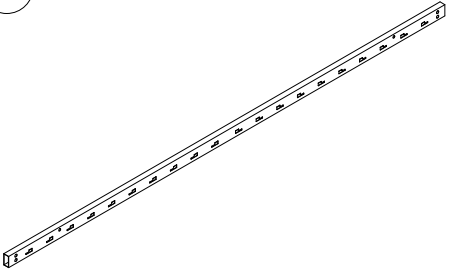
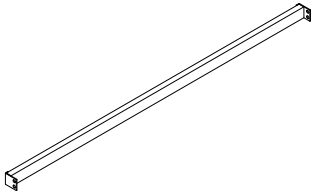
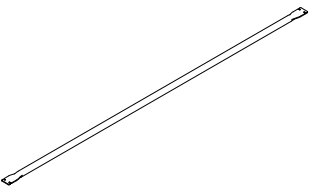
⚠ Before throwing any packaging, please verify all contents and make sure you have received all the parts listed above!

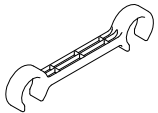
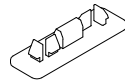
PARTS LIST FOR TRUNDLE

			
Side Rail 2 PCS	End Rail 2 PCS	Slat 20 PCS	Locking Caster 2 PCS
			
Caster 2 PCS	Slat Spacer 19 PCS	Plastic Plug 40 PCS	Slat Spacer 20 PCS

PART NUMBERS		
PART LABELS	4009059(Black)	4009219(Gold)
E	T949290	T951680
M	T910390	T947200
O	T919600	T945890
N1	T949300	T949270
N	T949310	T949280
Q	T919490	T919490
Y	T392590	T392590
W	T919480	T919480

⚠ Each part has a unique part number. Please reference the appropriate part number when contacting customer service for replacement parts.

⚠ Before throwing any packaging, please verify all contents and make sure you have received all the parts listed above!

HARDWARE LIST FOR DAYBED

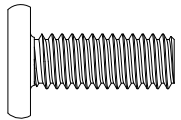
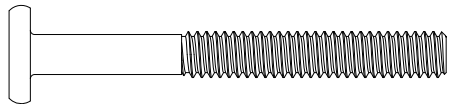
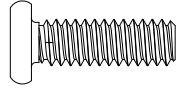
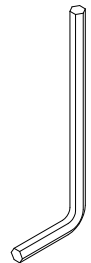
<p>1</p> 	<p>2</p> 	<p>3</p> 	<p>4</p> 
<p>5/16" X 3/4" 8 PCS</p>	<p>1/4" X 2 3/16 4 PCS</p>	<p>1/4" X 3/4" 8 PCS</p>	<p>4mm 1 PC</p>



Hardware Pack

4009059(Black)	<input checked="" type="checkbox"/> HP#: T4009059-00
4009219(Gold)	<input type="checkbox"/> HP#: T4009219-00

 Please do not completely tighten all the hardware, until the entire assembly is complete, unless otherwise indicated in the step-by-step instructions.

 The screw(s), bolt(s) to be used at each step are shown in actual size in the lower right corner of the page.

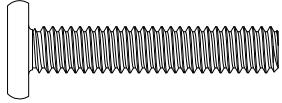
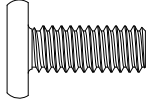
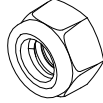
HARDWARE LIST FOR TRUNDLE

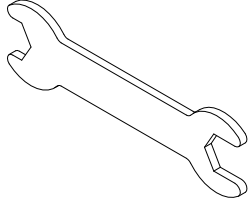
<p>1</p> 	<p>2</p> 	<p>3</p> 	<p>4</p> 	<p>5</p> 
<p>1/4" X 1 5/16" 4 PCS</p>	<p>1/4" X 5/8" 8 PCS</p>	<p>1/4" 4 PCS</p>	<p>4mm 1 PC</p>	<p>Wrench 1 PC</p>

Hardware Pack

4009059(Black)	<input checked="" type="checkbox"/> HP#: T5585196-02
4009219(Gold)	<input type="checkbox"/> HP#: T5585096-02



Please do not completely tighten all the hardware, until the entire assembly is complete, unless otherwise indicated in the step-by-step instructions.



The screw(s), bolt(s) to be used at each step are shown in actual size in the lower right corner of the page.

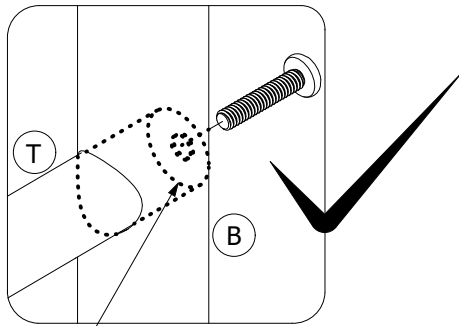

▲ **Correct:** Part T penetrating through Part A,B,C&D.

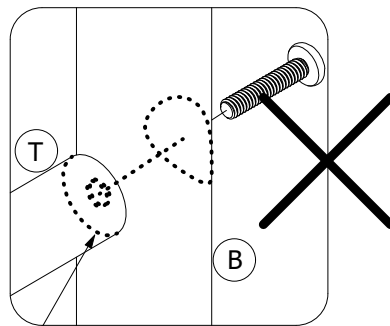

▲ **Incorrect:** Part T NOT penetrating through Part A,B,C&D.

Step 1

The following instructions will illustrate how to assemble the Daybed from **Step 1** to **Step 7**.

Please use the Daybed Hardware Pack on **Page 7**.

Orient parts **T/A/B/C/D** as illustrated.

Insert T x 2 into **A/B** and **C/D** with **3**.

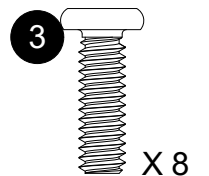
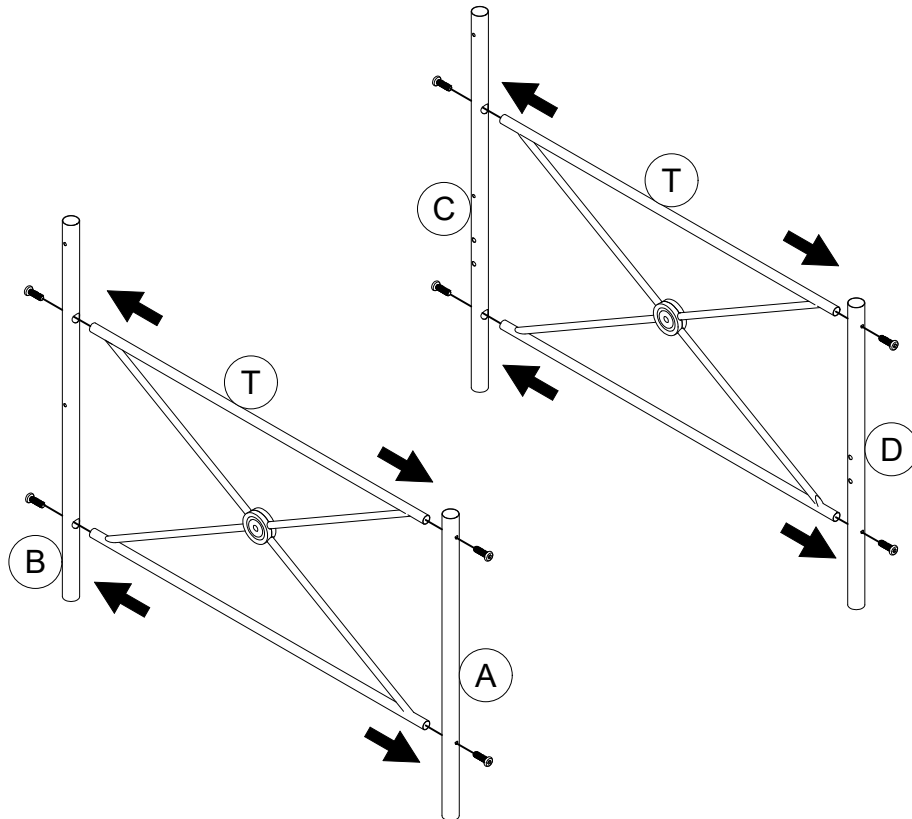

Step 2

Attach **J** x 2 to **A/B/C/D** with **1**.

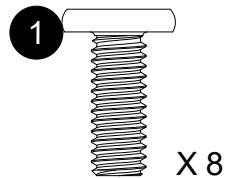
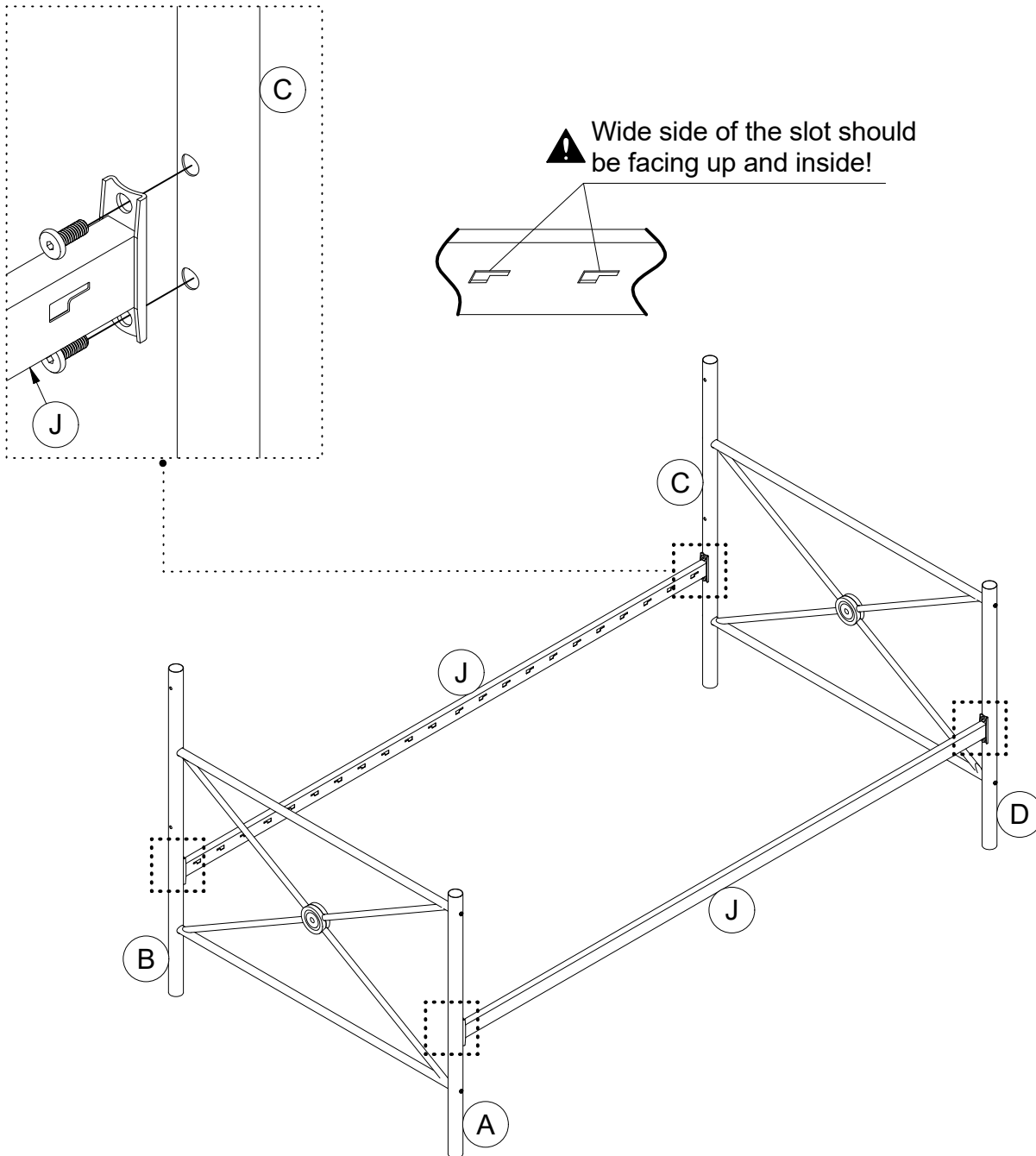

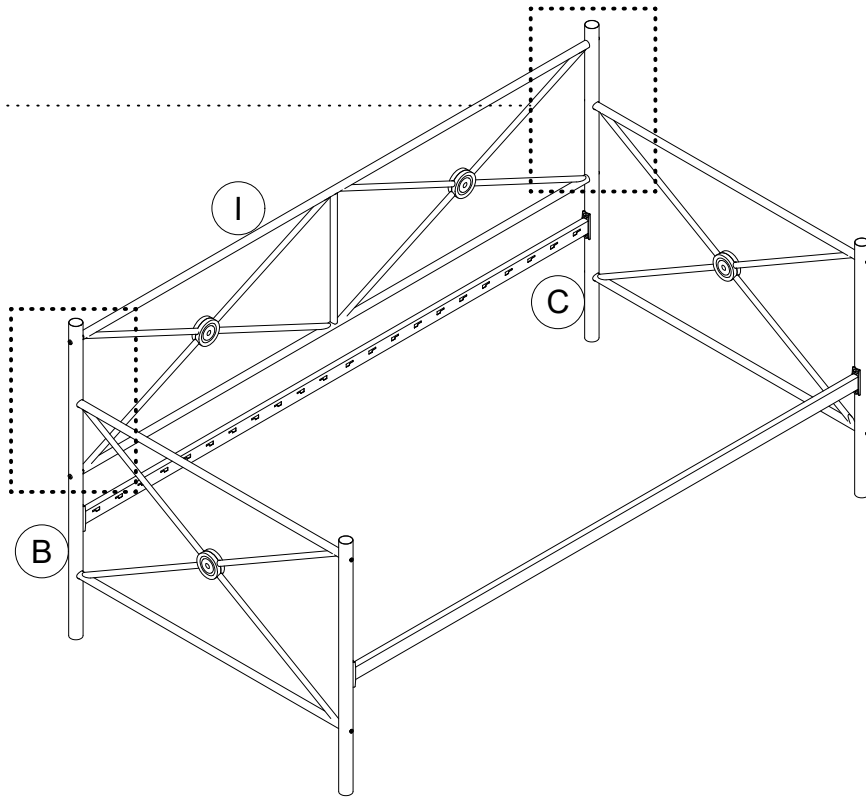
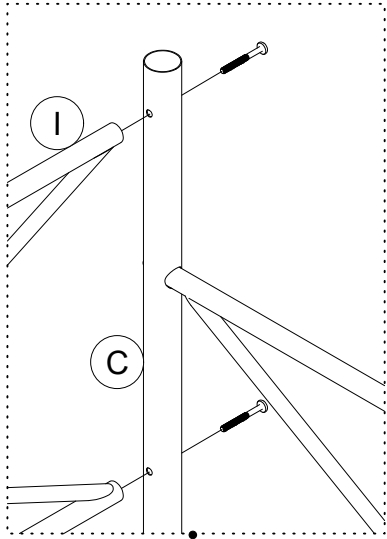

Step 3

Attach I to B/C with ②.

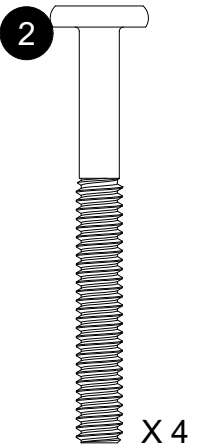

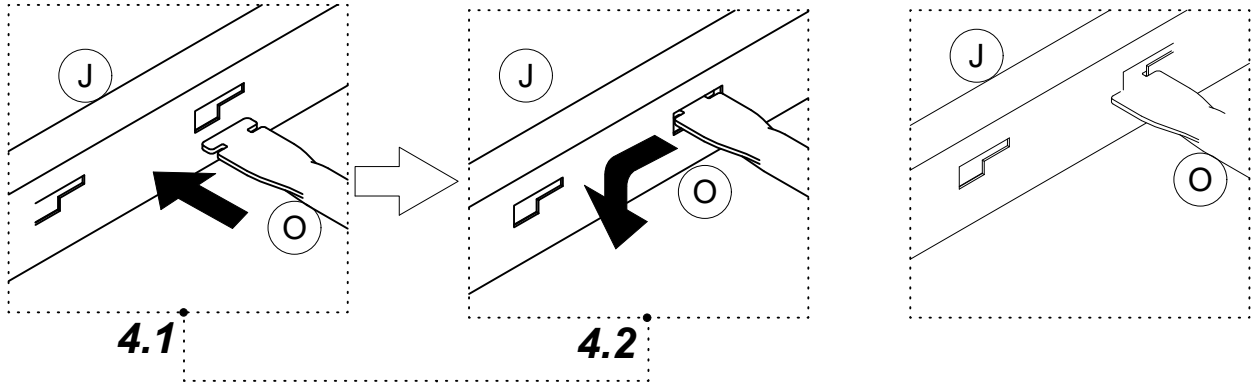

Step 4

- 4.1** Insert **O** into **J** X 2 as illustrated.
- 4.2** Slip **O** into place by sliding to the side and down.

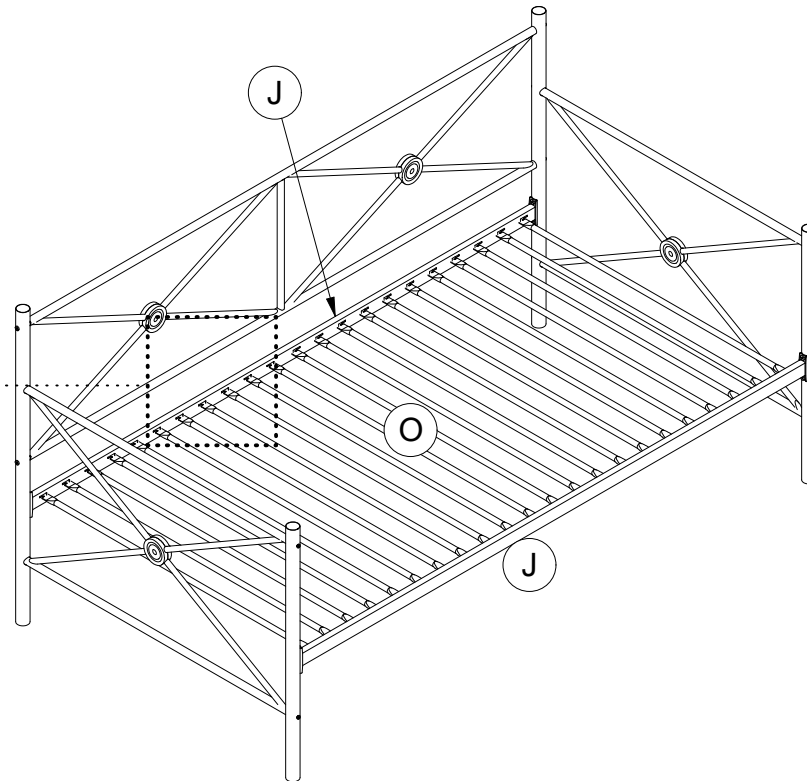

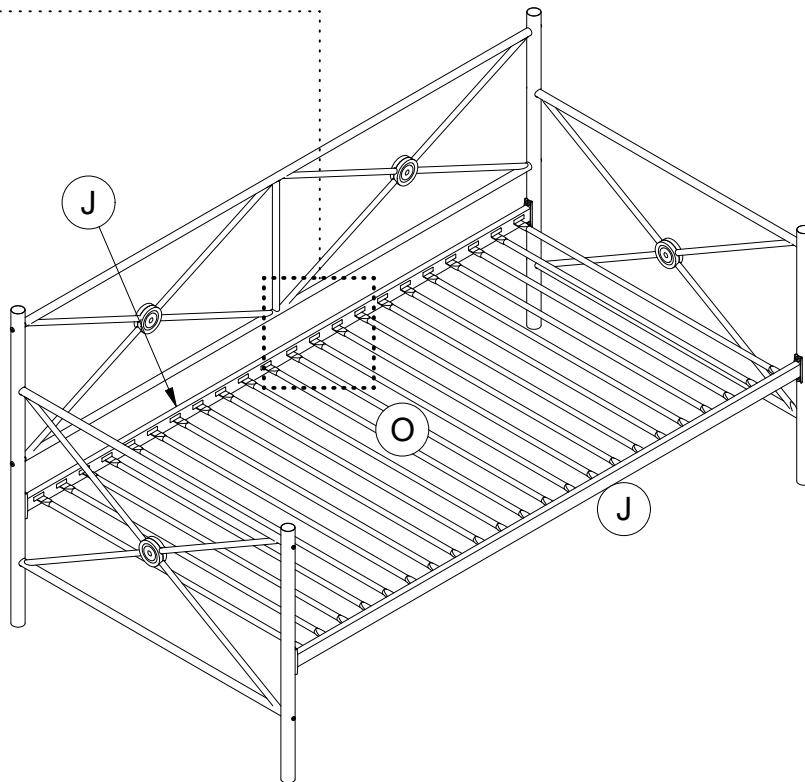
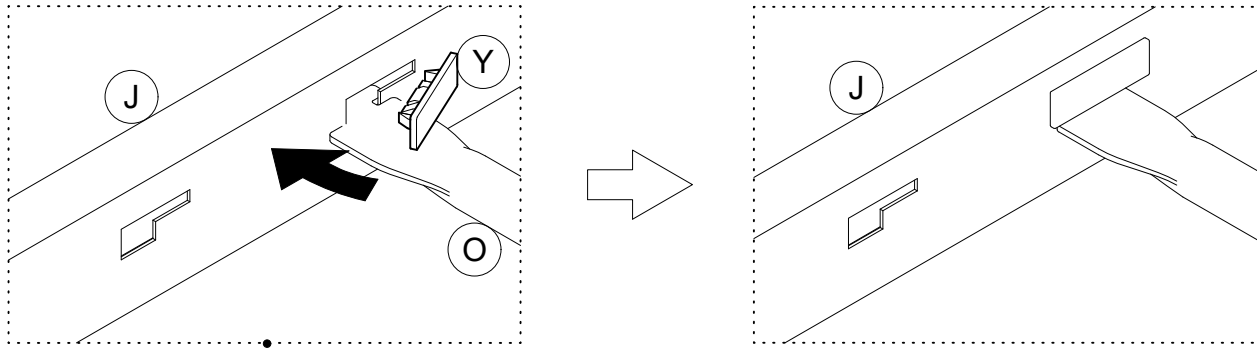

Step 5

Lock **O** with **Y** on the longer slot.

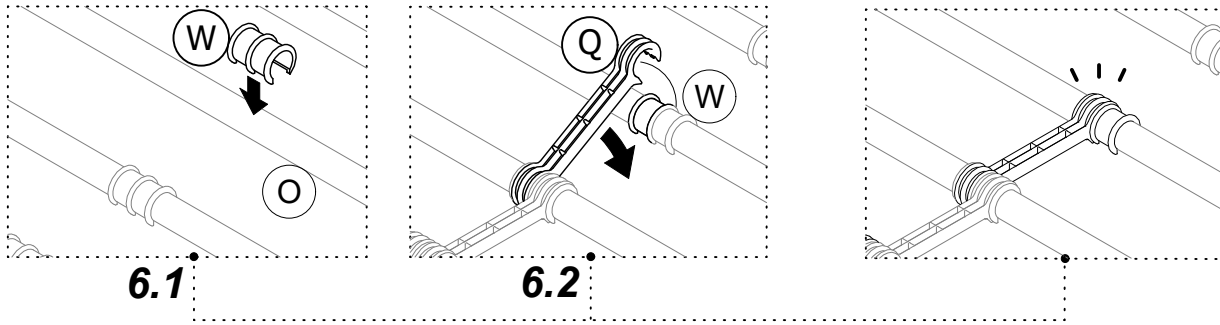

Step 6

6.1 Press **W** onto the middle of **O** as illustrated.

6.2 Press **Q** onto **W** alternating left and right.

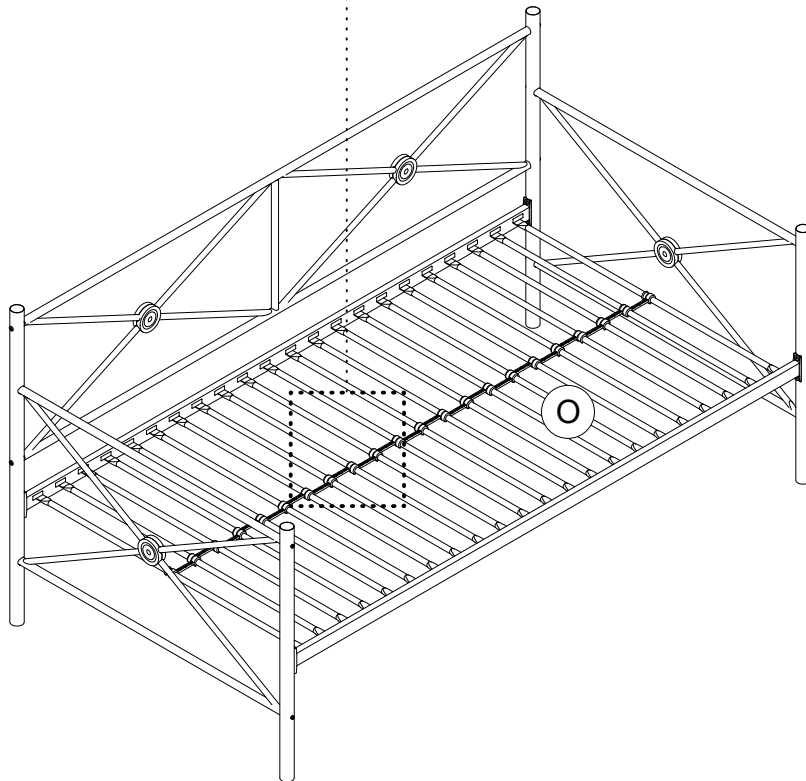

Step 7

Attach **S** x 4 to **A/B/C/D**.

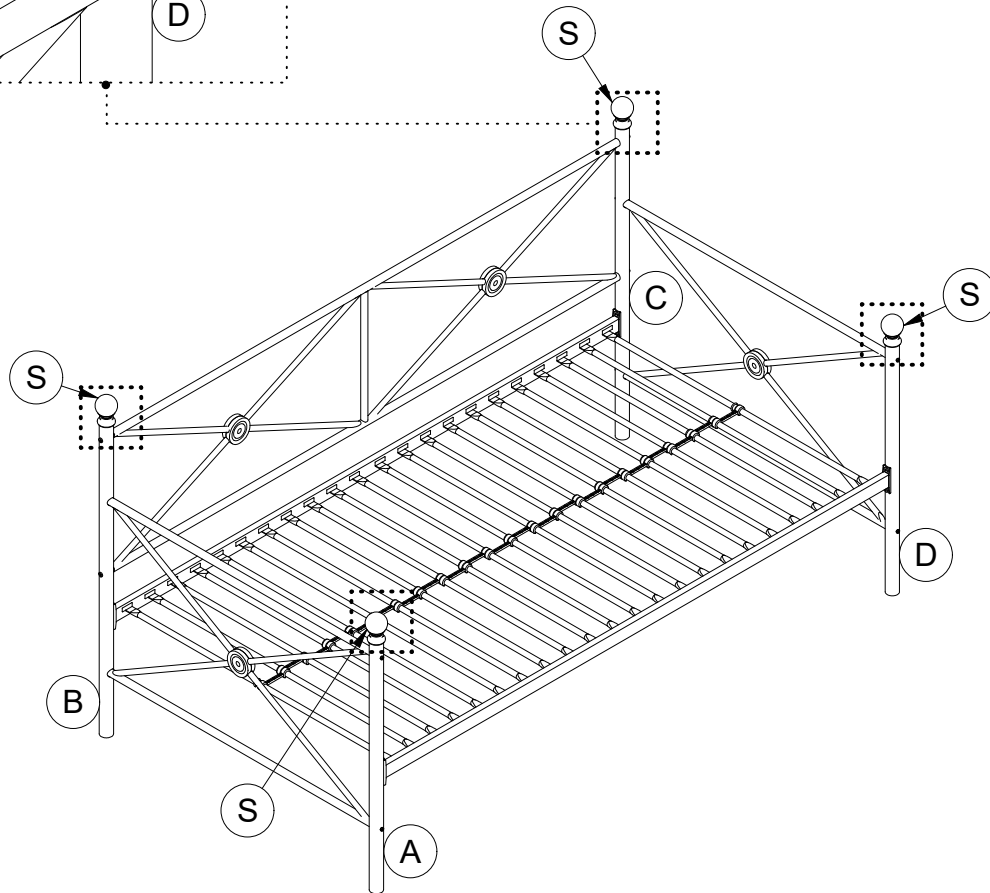
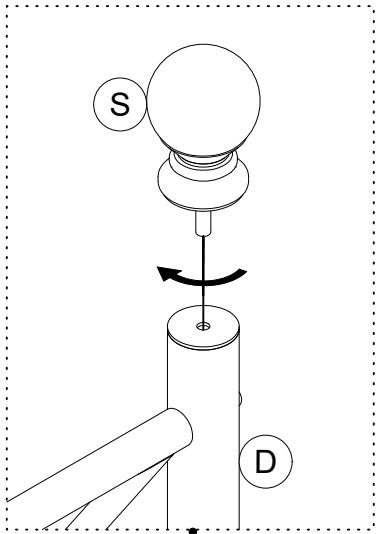

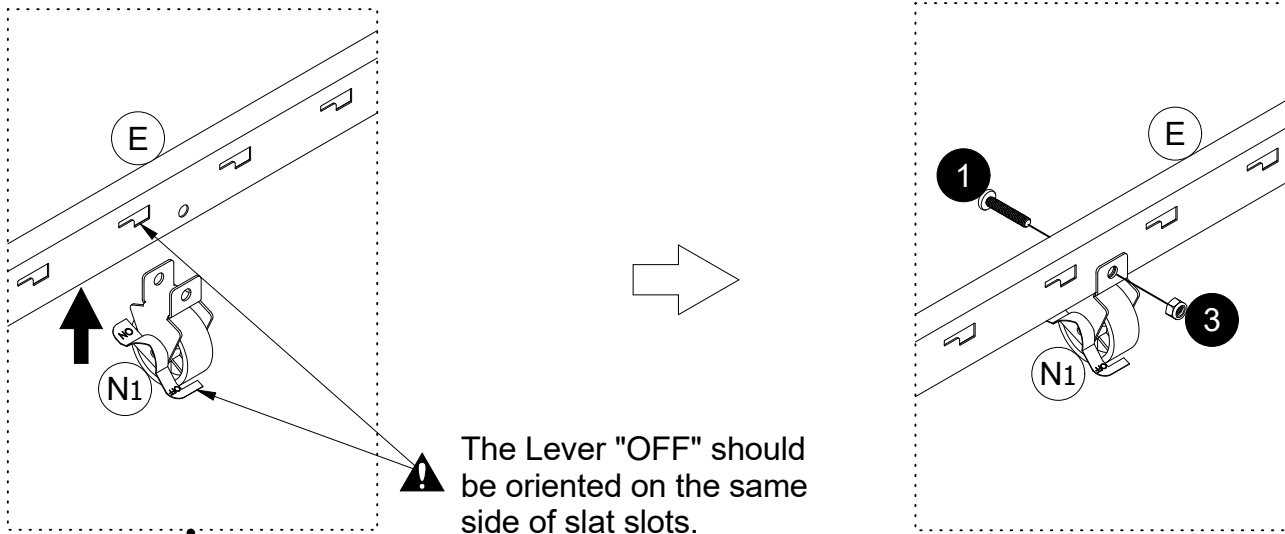

The Lever "OFF" should be oriented on the same side of slat slots.

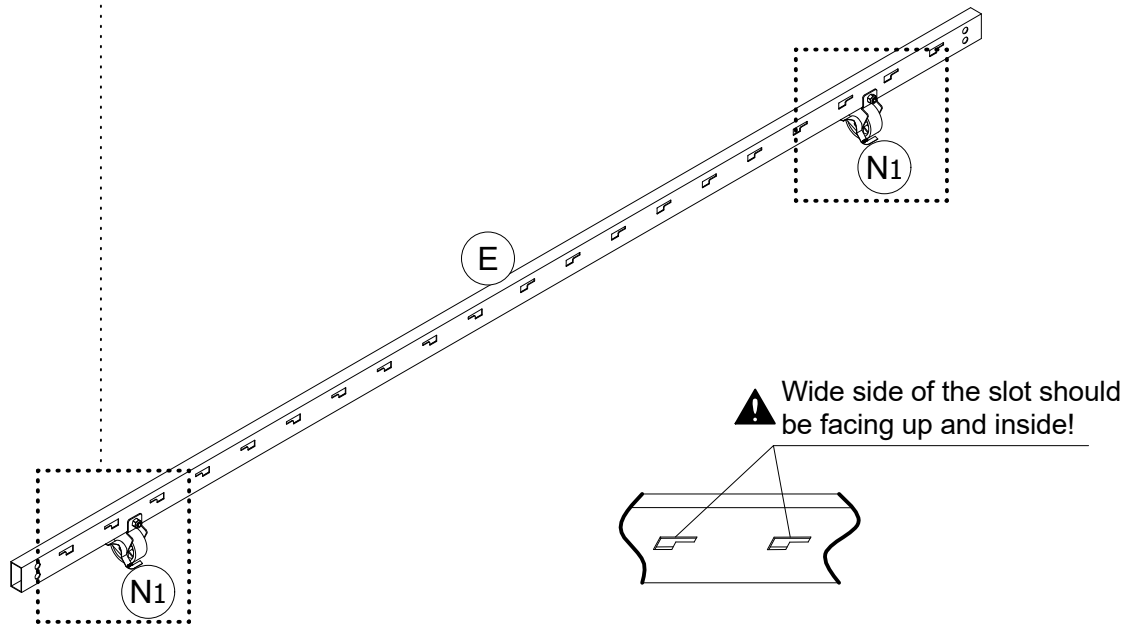

Wide side of the slot should be facing up and inside!

Step 8

The following instructions will illustrate how to assemble the Trundle from **Step 8** to **Step 13**.
Please Use the Trundle Hardware Pack on **Page 8**.

Attach **N1** x 2 to one of **E** with **1** and **3**.

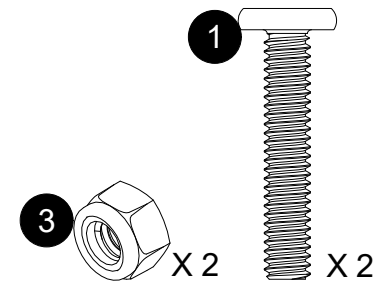

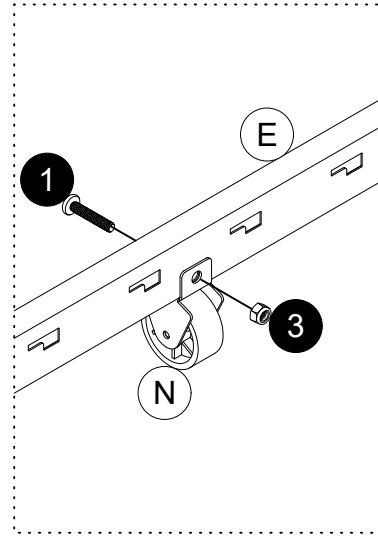
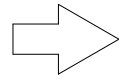
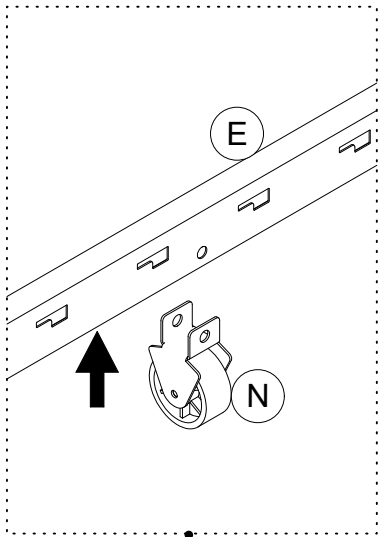

Step 9

Attach N x 2 to the other E with 1 and 3.

 Wide side of the slot should be facing up and inside!

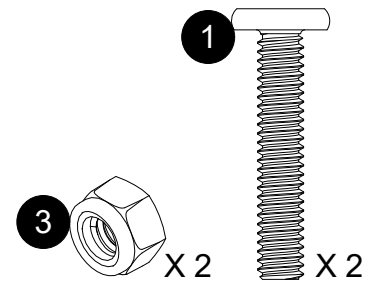
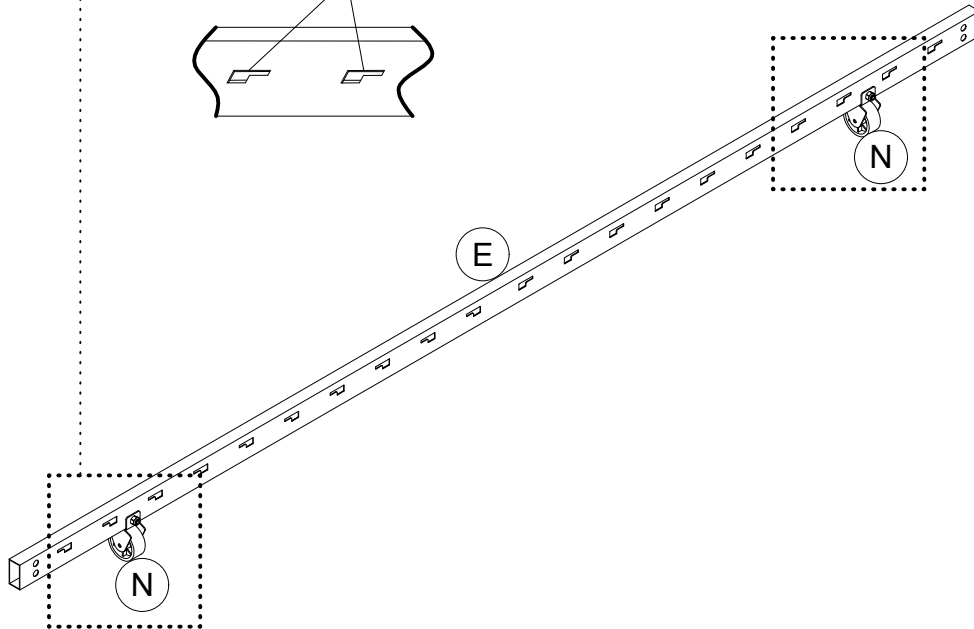
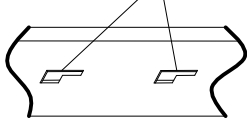

Step 10

Attach **M** x 2 to **E** x 2 with **2**.

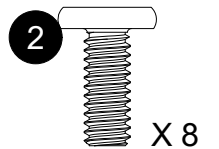
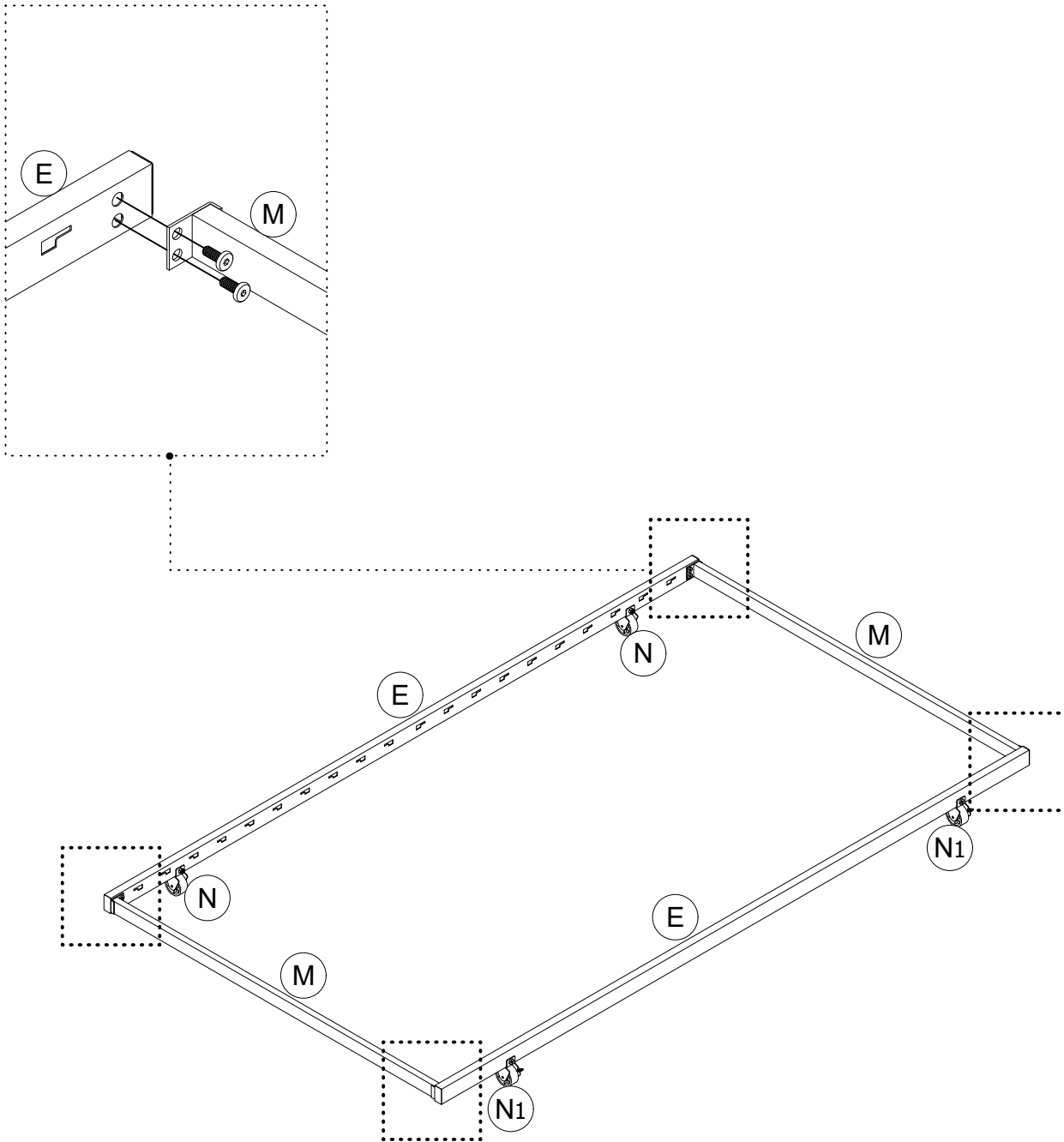

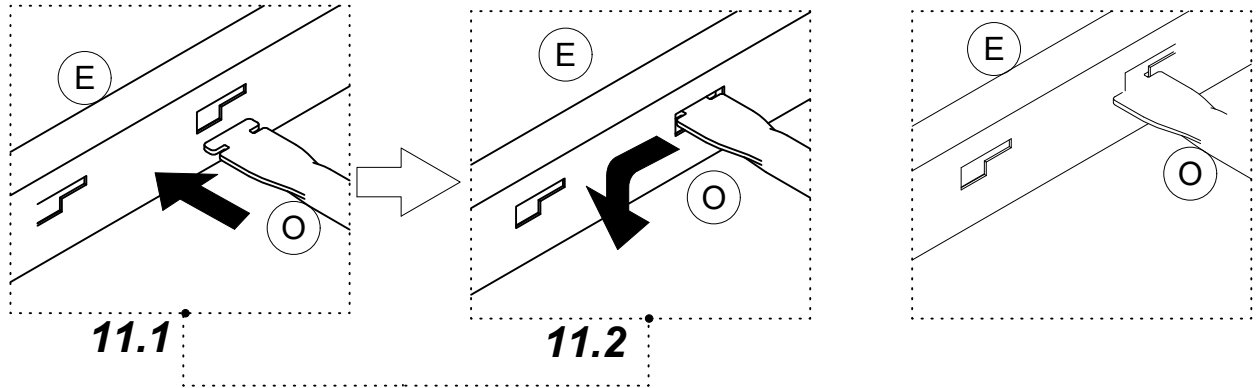

Step 11

11.1 Insert **O** into **E X 2** as illustrated.
11.2 Slip **O** into place by sliding to the side and down.

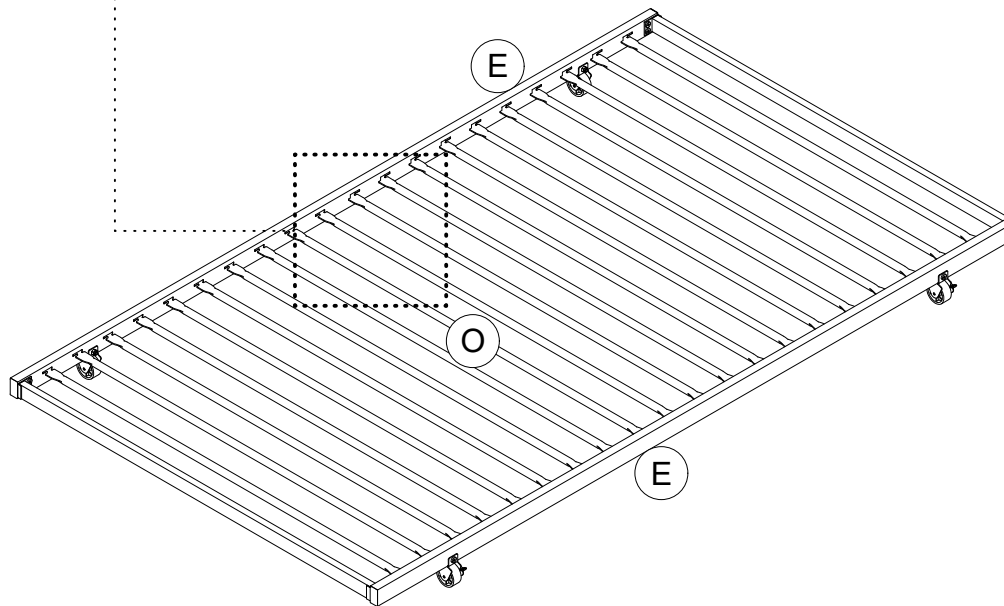

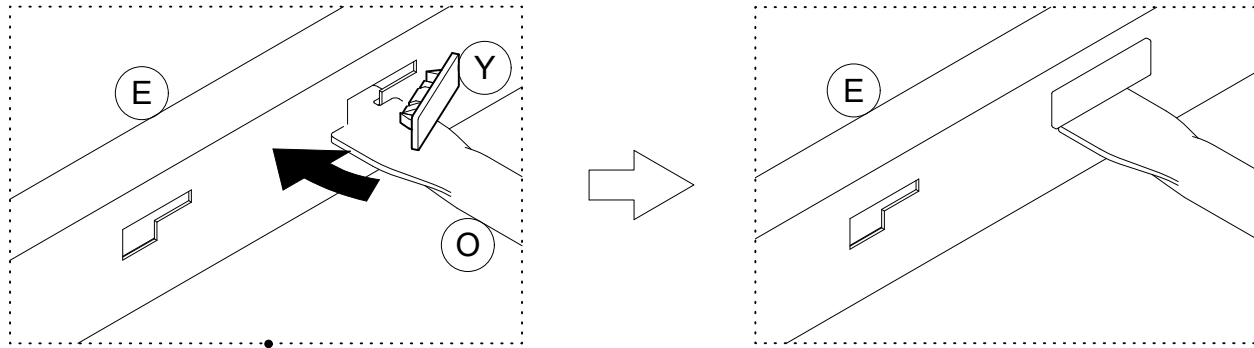

Step 12

Lock **O** into place with **Y** on the longer slot.

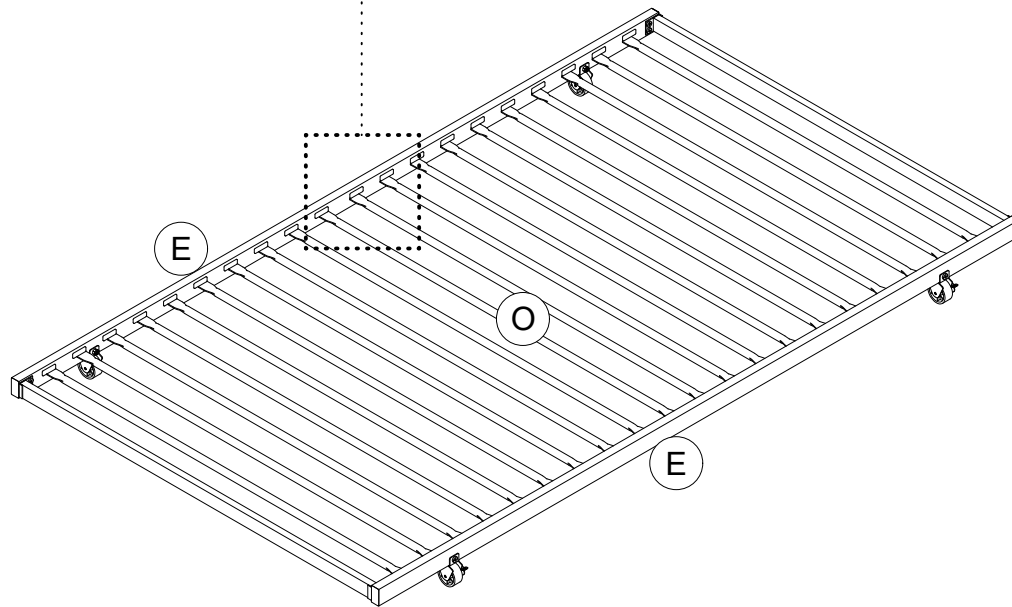

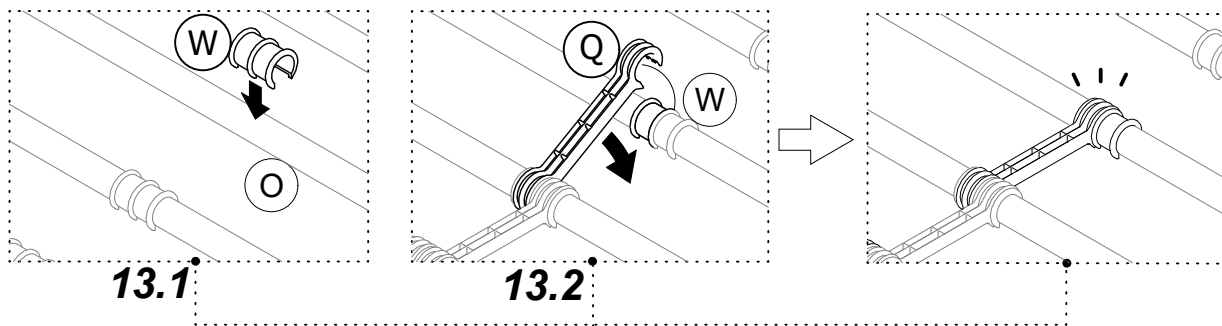

Step 13

13.1 Press **W** onto the middle of **O** as illustrated.

13.2 Press **Q** onto **W** alternating left and right.

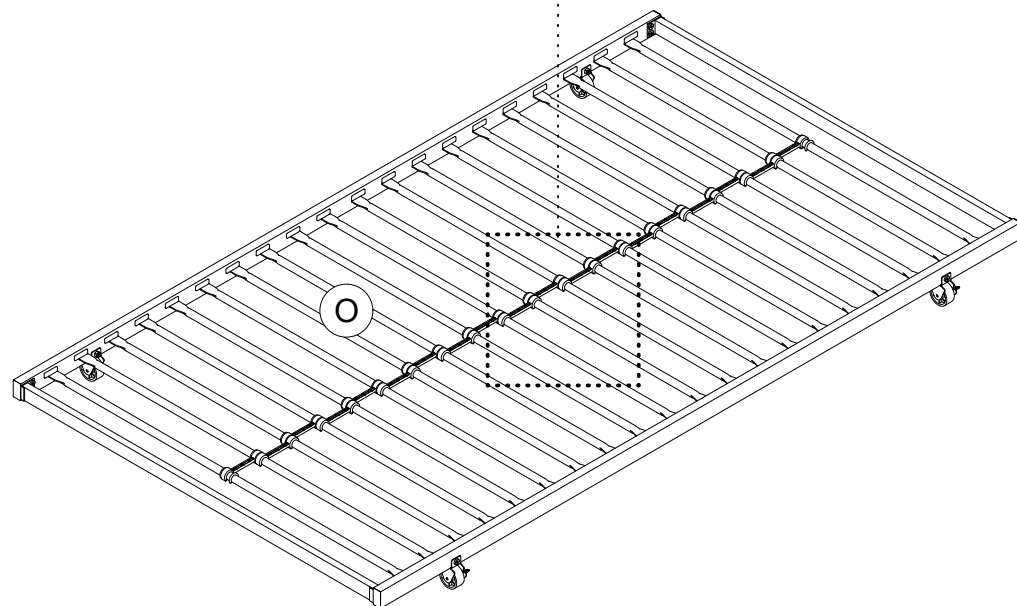

How to lock caster!

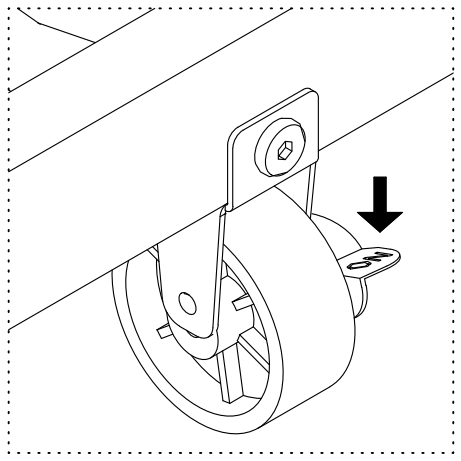

How to unlock caster!

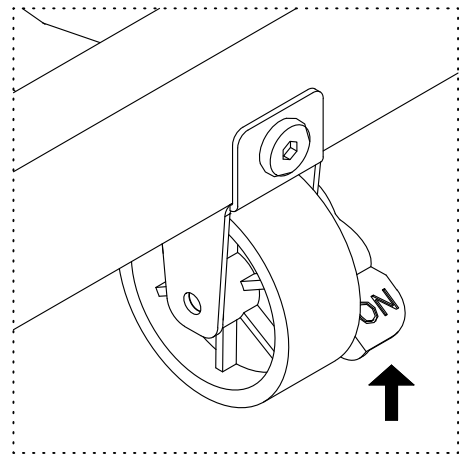

Helpful Hints

To use Trundle:

Pull out the trundle completely from underneath daybed. Once positioned, make sure casters are locked by pushing down the lever "ON" as illustrated "How to lock caster!".

To store Trundle:

Unlock the casters by pulling up the lever "ON" as illustrated "How to unlock caster!" and push in the Trundle underneath the Daybed.

WARNINGS:

Keep casters in lock condition under normal use to prevent unintentional movement which may lead to instability and tipping.

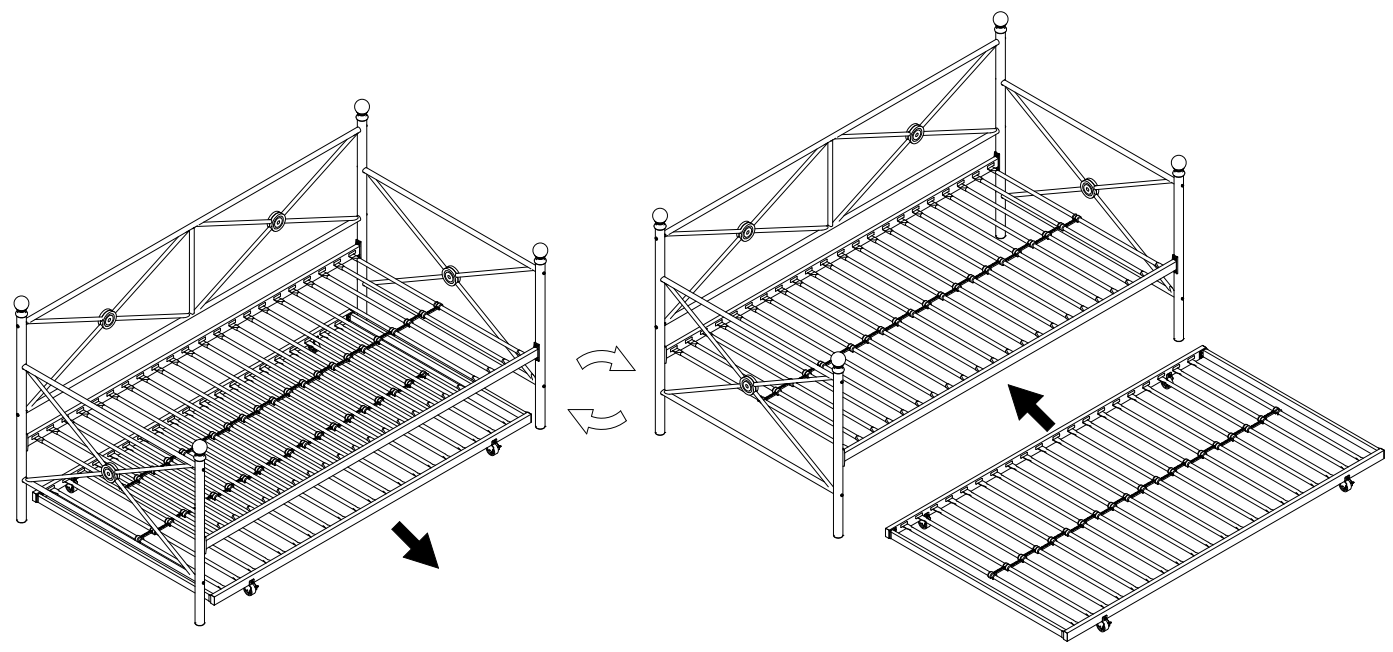

⚠ CAUTION: This unit is intended for use only with the products and/or maximum weights indicated. Use with other products and/or products heavier than the maximum weights indicated may result in instability or cause possible injury.

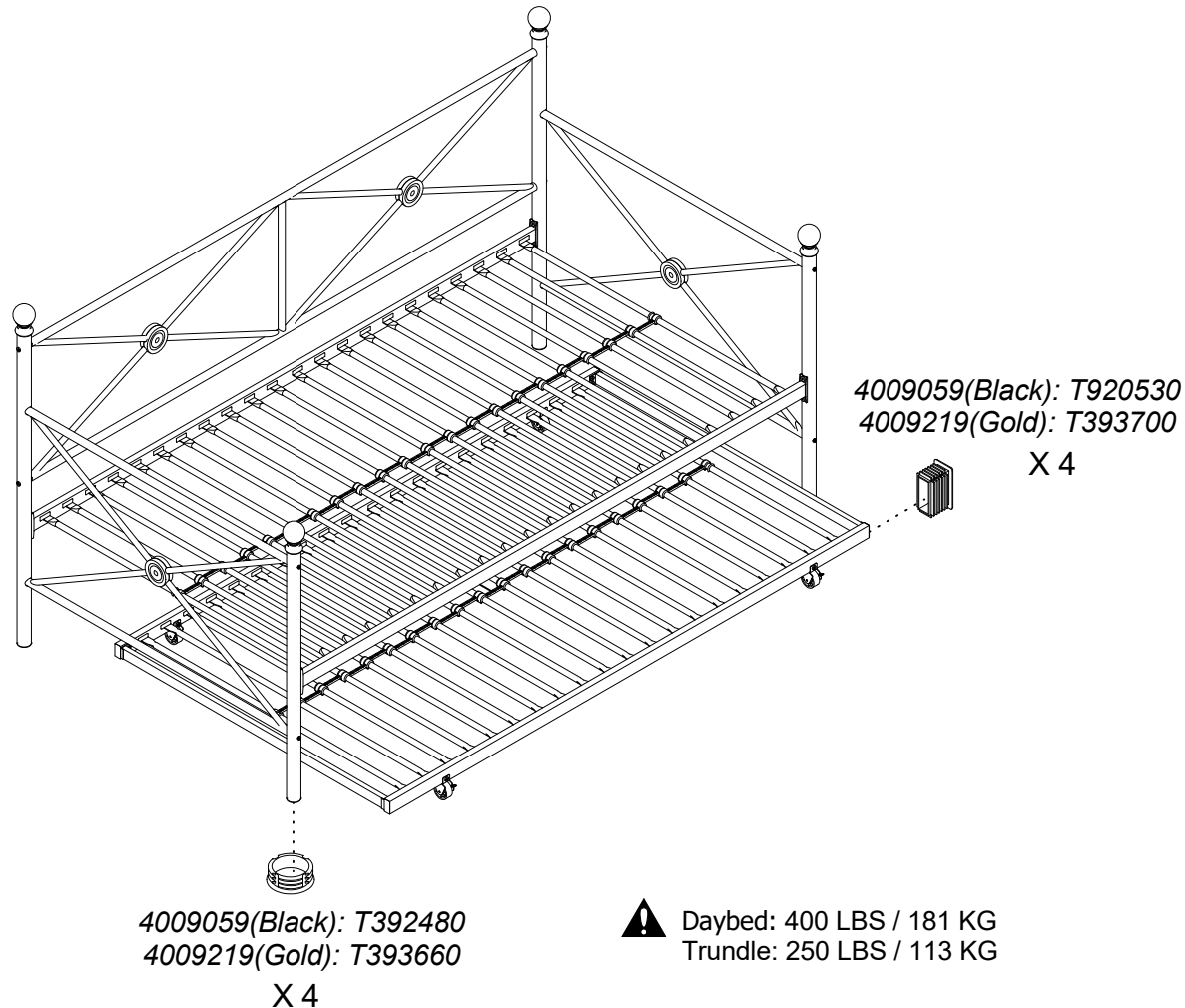

Helpful Hints

- Move your new furniture carefully, with two people lifting and carrying the unit to its new location.
- Your furniture can be disassembled and reassembled to move.
- Some parts have been pre-assembled for this item. They are illustrated on this page and available for replacement.
- Check bolts and nuts periodically and tighten if necessary.

⚠ WARNINGS:

For safety reasons and to prevent injuries:

- This bed is not intended for use by children under 4 years old.
- Prohibit jumping and horseplay on this bed.
- Only use a mattress which is **74" - 75"** long and **37½" - 38½"** wide on daybed.
- To optimize use of trundle, use a standard twin size mattress which is **74" - 75"** long and **37½" - 38½"** wide, no thicker than **8"**.
- Do not use risers under this bed.

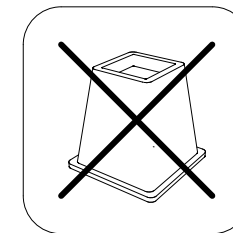

That's it ! You've finished assembling your **Metal Daybed and Trundle!**

4009059(Negro), 4009219(Oro)

Divián con Cama deslizable Individual/Individual

Fecha de compra

Número de lote

¡Gracias por tu compra DHP!

Información sobre la garantía

DHP garantiza que este producto está libre de defectos de material y mano de obra y se compromete a remediar cualquier defecto de este tipo. Esta garantía cubre 1 año a partir de la fecha de compra original. Esta garantía es válida solamente con presentación de una prueba de compra. Esto se limita a la reparación o reemplazo de componentes defectuosos del mueble y no se incluye ningún trabajo de ensamblaje.

Esta garantía no se aplica a ningún producto que haya sido mal ensamblado, sujeto a mal uso o abuso, o que haya sido alterado o reparado de cualquier manera. Cualquier uso, rotura o pérdida de color de la tela no están incluidos en esta garantía (donde corresponda). Esta garantía le da derechos legales específicas y usted puede también tener otros derechos que varían de estado a estado o de provincia a provincia.

Para obtener el servicio de garantía, debe presentar la factura original de su compra. Los componentes reparados o reemplazados están garantizados durante el periodo original de la garantía. Las partes defectuosas serán reparadas o reemplazadas sin cargo extra y sujetas a los términos y condiciones descritos anteriormente. Los términos y condiciones de la garantía limitada están sujetos a cambios sin previo aviso. Para conocer la política de garantía más reciente, visite www.dhpfurniture.com.

Precauciones

- Este producto está diseñado para uso doméstico y no para uso comercial.
- **ADVERTENCIA PARA NIÑOS PEQUEÑOS** - Este producto contiene componentes pequeños. Por favor asegúrese de que las piezas estén fuera del alcance de los niños.
- No utilice herramientas eléctricas para ensamblar su mueble. Este tipo de herramientas pueden rasgar o dañar las partes.

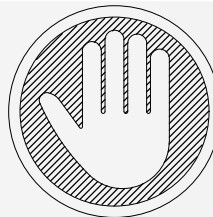

Preguntas, inquietudes, partes que faltan? CONTACTE NUESTRO DEPARTAMENTO DE SERVICIO AL CLIENTE ANTES DE DEVOLVER EL PRODUCTO A LA TIENDA.

Si le faltan piezas o las que se incluyen están dañadas, con mucho gusto le enviaremos sus piezas de reemplazo sin cargo extra.

Visite www.dhpfurniture.com/spa/replacement-parts, llame gratis al **1-800-267-1739** o chatea con nosotros al www.dhpfurniture.com



ESTE INSTRUCTIVO CONTIENE INFORMACION **IMPORTANTE** DE SEGURIDAD. POR FAVOR LEA Y GUARDE PARA SU REFERENCIA FUTURA.

Lea antes de comenzar a ensamblar

- Llame a nuestro número gratuito si necesita asistencia.
- Trabaje en un área espaciosa y cerca de donde su producto será utilizado, preferiblemente sobre una alfombra o utilice el cartón del empaque para proteger su piso y su producto.
- **El número de personas recomendadas para el montaje de este producto es: 2** (sin embargo es recomendable contar con ayuda adicional).
- **Tiempo estimado de ensamble es: 1.5Horas.**
- Asegúrese de que todas las partes están incluidas. La mayoría de las partes están etiquetadas o selladas en los bordes.
- Lea cada paso cuidadosamente. Es muy importante que cada paso de las instrucciones sea realizado en el orden correcto. Si estos pasos no se siguen en secuencia, pueden ocurrir dificultades durante el ensamblado.

¡Contáctenos!

Para solicitar ayuda con el ensamblaje, identificación de partes, información del producto o simplemente ordenar otras partes, diríjase a:

- Chatea con nosotros : www.dhpfurniture.com
- cs@dhpfurniture.com
- 1-800-267-1739
- Lunes - Viernes / **9 am - 9 pm** (hora del este)
- Sábado / **10 am - 6:30 pm** (hora del este)
- Domingo / **11 am - 7 pm** (hora del este)
- DHP Servicios al Cliente
- 12345 Albert Hudon, Suite 100, Montreal, Quebec, Canada, H1G 3L1

Partes

Piezas de reemplazo, visite www.dhpfurniture.com/spa/replacement-parts

IMPORTANTE: La lista de números de piezas que aparece a continuación es exclusiva de su producto. Por favor, manténgalo a mano cuando solicite piezas de repuesto.

 **Todo se incluye en 1 caja(s) grande(s)!**

 **Antes de deshacerse de las cajas de cartón, asegúrese de que estén vacías. También confirme que ha recibido todos los componentes necesarios para el ensamblaje al compararlos con la tabla de piezas indicadas en la sección en inglés.**

Paquete de componentes

Paquete #:

4009059(Negro)	<input checked="" type="checkbox"/> T4009059-00
4009219(Oro)	<input type="checkbox"/> T4009219-00

 **Nota:** Por favor no apriete completamente los pernos hasta que el ensamblaje sea completado, a menos de que se indique específicamente en cada paso de las instrucciones.

 Los tornillo(s), perno(s) que se utilizan en cada paso se muestran en tamaño real en la esquina inferior derecha de cada página.

NÚMERO DE PIEZA: CAMA			
ETIQUETAS DE PIEZAS	DESCRIPCIÓN	4009059 (Negro)	4009219 (Oro)
A	Poste	T926040	T958020
B	Poste	T926050	T958030
C	Poste	T926060	T958040
D	Poste	T926070	T958050
I	Barandal Trasero	T926080	T958060
T	Barandal Lateral	T926100	T958070
J	Barandal Delantero	T922140	T947170
O	Tubo	T919600	T945890
Q	Separador para tubo	T919490	T919490
Y	Cubiertas de plástico	T392590	T392590
W	Separador para tubo	T919480	T919480
S	Perilla	T925650	T946790

Partes

Piezas de reemplazo, visite www.dhpfurniture.com/spa/replacement-parts

IMPORTANTE: La lista de números de piezas que aparece a continuación es exclusiva de su producto. Por favor, manténgalo a mano cuando solicite piezas de repuesto.

 **Todo se incluye en 1 caja(s) grande(s)!**

 **Antes de deshacerse de las cajas de cartón, asegúrese de que estén vacías. También confirme que ha recibido todos los componentes necesarios para el ensamblaje al compararlos con la tabla de piezas indicadas en la sección en inglés.**

Paquete de componentes

Paquete #:

4009059(Negro)	<input checked="" type="checkbox"/> T5585196-02
4009219(Oro)	<input type="checkbox"/> T5585096-02

 **Nota:** Por favor no apriete completamente los pernos hasta que el ensamblaje sea completado, a menos de que se indique específicamente en cada paso de las instrucciones.

 Los tornillo(s), perno(s) que se utilizan en cada paso se muestran en tamaño real en la esquina inferior derecha de cada página.

NÚMERO DE PIEZA: CAMA DESLIZABLE			
ETIQUETAS DE PIEZAS	DESCRIPCIÓN	4009059(Negro)	4009219(Oro)
E	Barandilla lateral	T949290	T951680
M	Barandal de extremo	T910390	T947200
O	Tubos	T919600	T945890
N1	Rueda con bloqueo	T949300	T949270
N	Rueda	T949310	T949280
Q	Separador para tubo	T919490	T919490
Y	Cubiertas de plástico	T392590	T392590
W	Separador para tubo	T919480	T919480

Instrucciones

Paso 1

Las instrucciones siguientes ilustrarán cómo ensamblar el Diván del Paso 1 al Paso 7.

Utilice el paquete **Daybed Hardware** en la página 7.

Oriente **T/A/B/C/D** como se ilustra

Insertar **T** x 2 dentro de **A/B & C/D** con ③.

Paso 2

Una **J** x 2 con **A/B/C/D** con ①.

Paso 3

Una **I** con **B/C** con ②.

Paso 4

4.1 Inserte **O** dentro de **J** x 2 como se ilustra.

4.2 Bloquee **O** en su lugar con **Y**.

Paso 5

5.1 Presione **W** sobre **O**.

5.2 Presione **Q** sobre **W** alternando de derecha a izquierda.

Paso 6

Una **S** x 4 con **A/B/C/D**.

Paso 7

Las siguientes instrucciones desde el paso 7 al paso 11 ilustran como ensamblar la cama inferior.

Por favor utilizar el paquete de componentes en la página 8.

Una **N1** x 2 con **E** usando ① y ③.

Paso 8

Una **N** x 2 con **E** usando ① y ③.

Paso 9

Una **M** x 2 con **E** x 2 con ②.

Paso 10

10.1 Inserte **O** dentro de **E** x 2 como se ilustra.

10.2 Bloquee **O** en su lugar con **Y**.

Paso 11

11.1 Presione **W** sobre **O**.

11.2 Presione **Q** sobre **W** alternando de derecha a izquierda.



Límites de peso:

Cama: 400 LBS / 181 KG

Cama deslizable: 250 LBS / 113 KG



PRECAUCIÓN: Esta unidad está diseñada para ser utilizada únicamente con los productos y/o pesos máximos indicados. Su uso con otros productos y/o productos más pesados que los pesos máximos indicados puede provocar inestabilidad o causar lesiones.

Consejos útiles

- Mueva sus muebles nuevos con cuidado, con dos personas levantando y llevando el aparato a su nueva ubicación.
- Sus muebles se pueden desmontar y volver a ensamblar en caso de mudanza.
- Algunas partes han sido pre-ensambladas en este producto. Se encuentran ilustradas en esta página y disponibles para reemplazo.
- Limpie el producto con un paño suave. NO utilice productos químicos o abrasivos de limpieza.
- Revise los pernos y tuercas periódicamente y apriete si es necesario.



PRECAUCIÓN

Por razones de seguridad y para prevenir lesiones:

- Este producto no ha sido diseñado para ser utilizado por niños menores de 4 años.
- Prohibido saltar o jugar sobre la cama.
- Utilice únicamente un colchón que sea de **74" - 75"** de largo y **37½" - 38½"** de ancho.
- Para optimizar el uso de la cama inferior, use un colchón de tamaño matrimonial que sea de **74" - 75"** de largo y **37½" - 38½"** de ancho y máximo 8" de espesor.
- No utilice elevadores para cama con este producto.

4009059(Noir), 4009219(Or)

Lit d'appoint en métal

Lit une place/Lit une place

Date d'achat

Numéro de lot

Merci d'avoir acheté un produit DHP !

Informations sur la garantie

DHP garantit que ce produit est exempt de tout vice de matériaux et de fabrication et s'engage à remédier à un tel défaut. Cette garantie est valable un an à compter de la date d'achat initiale. Elle se limite uniquement à la réparation ou au remplacement des pièces défectueuses. La main-d'oeuvre nécessaire à l'assemblage n'est pas incluse.

Cette garantie ne s'applique pas aux produits qui ont été mal assemblés, qui ont été soumis à une utilisation abusive ou qui ont subi des modifications ou des réparations. La garantie ne couvre pas l'usure, les déchirures ou la décoloration du tissu (le cas échéant). La responsabilité pour les dommages indirects est exclue quand l'exclusion est autorisée par la loi. Cette garantie vous confère des droits spécifiques légaux. Il se peut que vous bénéficiiez de droits additionnels car ceux-ci peuvent varier selon l'État ou la province.

Pour bénéficier du service de garantie, l'acheteur doit présenter la facture originale. Les composants réparés ou remplacés sont garantis jusqu'à la fin de la période de la garantie initiale uniquement. Les composants défectueux seront réparés ou remplacés sans frais, sous réserve des conditions décrites ci-dessus. Les termes et conditions de la garantie limitée sont susceptibles d'être modifiés sans préavis. Pour connaître la dernière politique de garantie, veuillez consulter le site www.dhpfurniture.com.

Précautions

- Ce produit est conçu pour un usage domestique et n'est pas destiné à des fins commerciales.
- **AVERTISSEMENT CONCERNANT LES JEUNES ENFANTS:** Ce produit contient des petits composants. S'il vous plaît assurez-vous qu'ils soient gardés loin d'eux.
- Ne pas utiliser d'outils électriques pour assembler votre mobilier. Ce type d'outils risque d'endommager les pièces.

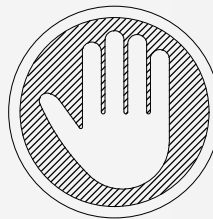

Des questions, des préoccupations ou des pièces manquantes? CONTACTEZ NOTRE SERVICE À LA CLIENTÈLE AVANT DE RETOURNER LE PRODUIT AU DÉTAILLANT.

Si des pièces sont manquantes ou endommagées, nous expédierons volontiers vos pièces de rechange gratuitement. Visitez www.dhpfurniture.com/eng/replacement-parts, appelez sans frais au **1-800-267-1739** ou clavardez avec nous au www.dhpfurniture.com.



CE FEUILLET CONTIENT DES INFORMATIONS DE SÉCURITÉ IMPORTANTES. S'IL VOUS PLAÎT LIRE ET CONSERVER POUR RÉFÉRENCE ULTÉRIEURE.

Avant de commencer l'assemblage

- Si vous avez besoin d'aide, appelez notre service à la clientèle sans frais.
- Travaillez dans un endroit spacieux et près du lieu où l'unité sera utilisée, préférablement sur un tapis, ou sur un morceau de l'emballage, afin de protéger le plancher et le produit.
- **Nombre de personnes recommandées pour l'assemblage : 2** (cependant il est toujours préférable d'être assisté par une personne supplémentaire).
- **Temps d'assemblage estimé : 1.5heures.**
- Assurez-vous d'avoir bien reçu toutes les pièces. La plupart de celles-ci sont étiquetées ou estampées sur leur côté non fini.
- Lire attentivement chaque étape avant de débiter. Il est très important que chaque étape de montage soit exécutée dans le bon ordre, sinon vous risquez d'éprouver de la difficulté à assembler votre meuble.

Contactez-nous!

Besoin d'aide pour assembler, identifier des pièces, vous informer sur le produit, ou pour commander des pièces Contactez-nous:

- Clavardez avec nous : www.dhpfurniture.com
- cs@dhpfurniture.com
- 1-800-267-1739
Lundi - Vendredi / 9 am - 9 pm (Heure de l'Est)
Samedi / 10 am - 6:30 pm (Heure de l'Est)
Dimanche / 11 am - 7 pm (Heure de l'Est)
- DHP Service à la Clientèle
12345 Albert Hudon, Suite 100, Montréal, Québec, Canada, H1G 3L1

Pièces

Pour des pièces de rechange, visitez
www.dhpfurniture.com/fre/replacement-parts

IMPORTANT: La liste des références ci-dessous est propre à votre produit.
Veuillez l'avoir sous la main lorsque vous appelez pour des pièces de rechange.

 **Tout dans 1 grande(s) boîte(s)!**

 **Avant de jeter les boîtes en carton, assurez-vous qu'elles soient vides. Vérifiez que vous avez reçu tous les composants nécessaires à l'assemblage en les comparant avec le tableau des pièces (illustrations disponibles dans la section en anglais).**

Quincaillerie

de paquet :

4009059(Noir)	<input checked="" type="checkbox"/> T4009059-00
4009219(Or)	<input type="checkbox"/> T4009219-00

 **Remarque:** Sauf indication contraire dans les instructions, ne pas resserrer complètement les vis et les boulons, jusqu'à ce que l'assemblage soit terminé.

 Les vis et boulons utilisés durant chaque étape sont illustrés en taille réelle au coin inférieur droit de la page.

NÚMERO DE PIEZA: CAMA

ETIQUETAS DE PIEZAS	DESCRIPCIÓN	4009059 (Noir)	4009219 (Or)
A	Poteau	T926040	T958020
B	Poteau	T926050	T958030
C	Poteau	T926060	T958040
D	Poteau	T926070	T958050
I	Garde Corps Arrière	T926080	T958060
T	Garde-corps Latéral	T926100	T958070
J	Avant Rail	T922140	T947170
O	Lamelle	T919600	T945890
Q	Entretoise latte	T919490	T919490
Y	Bouchon de plastique	T392590	T392590
W	Entretoise latte	T919480	T919480
S	Balle	T925650	T946790

Pièces

Pour des pièces de rechange, visitez
www.dhpfurniture.com/fre/replacement-parts

IMPORTANT: La liste des références ci-dessous est propre à votre produit.
Veuillez l'avoir sous la main lorsque vous appelez pour des pièces de rechange.

 **Tout dans 1 grande(s) boîte(s)!**

 **Avant de jeter les boîtes en carton, assurez-vous qu'elles soient vides. Vérifiez que vous avez reçu tous les composants nécessaires à l'assemblage en les comparant avec le tableau des pièces (illustrations disponibles dans la section en anglais).**

Quincaillerie

de paquet :

4009059(Noir)	<input checked="" type="checkbox"/> T5585196-02
4009219(Or)	<input type="checkbox"/> T5585096-02

 **Remarque:** Sauf indication contraire dans les instructions, ne pas resserrer complètement les vis et les boulons, jusqu'à ce que l'assemblage soit terminé.

 Les vis et boulons utilisés durant chaque étape sont illustrés en taille réelle au coin inférieur droit de la page.

NÚMERO DE PIEZA: CAMA DESLIZABLE			
ETIQUETAS DE PIEZAS	DESCRIPCIÓN	4009059(Noir)	4009219(Or)
E	Rail latéral	T949290	T951680
M	Entretoise de fin	T910390	T947200
O	Lamelles	T919600	T945890
N1	Roulette de verrouillage	T949300	T949270
N	Roulette	T949310	T949280
Q	Entretoise latte	T919490	T919490
Y	Bouchon de plastique	T392590	T392590
W	Entretoise latte	T919480	T919480

Instructions

Étape 1

Les instructions suivantes illustrent comment assembler le Lit de jour (étape 1 à 7).

S'il vous plaît utiliser la Quincaillerie pour Lit de Jour, (illustration: **page 7**).

Placer **T/A/B/C/D**, tel qu'illustré.

Insérer **T** x 2 dans **A/B** & **C/D** avec ③.

Étape 2

Attacher **J** x 2 dans **A/B/C/D** avec ①.

Étape 3

Attacher **I** dans **B/C** avec ②.

Étape 4

4.1 Insérer **O** dans **J** x 2, tel qu'illustré.

4.2 Verouiller la position de **O** avec **Y**.

Étape 5

5.1 Pousser **W** sur le milieu de **O**, tel qu'illustré.

5.2 Pousser **Q** sur **W**, en alternant de gauche à droite.

Étape 6

Attacher **S** x 4 à **A/B/C/D**.

Étape 7

Les instructions suivantes illustrent comment assembler le Lit Gigogne (lit inférieur) (étape 7 à 11).

S'il vous plaît utiliser la Quincaillerie pour Lit Gigogne (illustration: **page 8**).

Attacher **N1** x 2 à **E** avec ① et ③.

Étape 8

Attacher **N** x 2 à **E** avec ① et ③.

Étape 9

Attacher **M** x 2 à **E** x 2 avec ②.

Étape 10

10.1 Insérer **O** dans **E** x 2, tel qu'illustré.

10.2 Verouiller la position de **O** avec **Y**.

Étape 11

11.1 Pousser **W** sur le milieu de **O**, tel qu'illustré.

11.2 Pousser **Q** sur **W**, en alternant de gauche à droite.

⚠ Limite de Poids:
Lit de jour: 400 LBS / 181 KG
Lit gigogne: 250 LBS / 113 KG

⚠ Cette unité est destinée à être utilisée uniquement avec les produits et/ou les poids maximum indiqués. L'utilisation avec d'autres produits et/ou des produits plus lourds que les poids maximum indiqués peut entraîner une instabilité ou causer des blessures.

Conseils utiles

- Déplacez votre nouveau mobilier avec soin, nous recommandons deux personnes pour soulever et transporter le mobilier vers son nouvel emplacement.
- Votre mobilier peut être démonté et reassemblé pour faciliter les déménagements.
- Certaines pièces (illustration disponible dans la section en anglais), sont pré-assemblées et disponibles au besoin pour un remplacement.
- Nettoyez le produit avec un chiffon doux. NE PAS utiliser de produits chimiques ou abrasifs.
- Vérifiez régulièrement les boulons et les écrous et resserrez-les si nécessaire.

⚠ AVERTISSEMENT

Pour des raisons de sécurité et afin de prévenir les blessures:

- Ce lit n'est pas conçu pour être utilisé par des enfants de moins de 4 ans.
- Interdire les sauts et les jeux de bataille sur le lit.
- Utilisez uniquement un matelas de **74" - 75"** de long par **37½" - 38½"** de large.
- Pour optimiser l'utilisation du lit inférieur, utilisez un matelas de grandeur double, soit de **74" - 75"** de long, **37½" - 38½"** de large et maximum de 8" d'épais.
- Ne pas utiliser un rehausseur de lit sous ce produit.